

激光焊接 Fiber Laser Welding

机器人激光焊接单元 | 三维五轴充气柜激光焊接机 | 机器人激光焊接系统 | 手持式激光焊接机

Robot Laser Welding System / Five-axis Laser Welding Machine / Robot Laser Welding System / hand Laser Welding Machine

**Yawei 亚威**

股票代码 002559

Stock Code 002559

YLRW系列 机器人激光焊接系统

YLRW Series Robot Laser Welding System

01 灵活的机械手 Flexible manipulator

根据用户要求选择KUKA、ABB、YASKAWA及FANUC等高精度机械手
According to user requirements to choose KUKA, ABB, YASKAWA, FANUC or other high-precision manipulator



02 匹配的变位机 Matched positioner

根据用户工件焊接要求可选择单轴、双轴、三轴或多轴焊接变位机
According to requirements of welding piece to choose single axis, two axis, three axis or multi-axis welding positioner

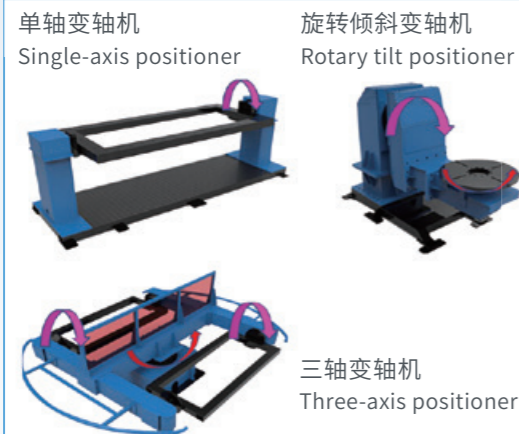

03 个性化定制焊接头 Customize welding head

根据不同材质、厚度、焊缝要求匹配自熔、填丝、摆动、振镜、复合焊接头
According to different material, thickness, welding seam to match self-melting, wire filling, swing, vibration mirror, composite welding head
Customize the welding joint



04 丰富的选配功能 Abundant optional functions

选配直线移动轴、焊缝跟踪功能、离线编程软件、焊接防护房及烟尘处理系统，轻松应对复杂工况
Linear moving shaft, welding seam tracking function, offline programming software, welding protection room and smoke treatment system, easy to deal with complex working condition

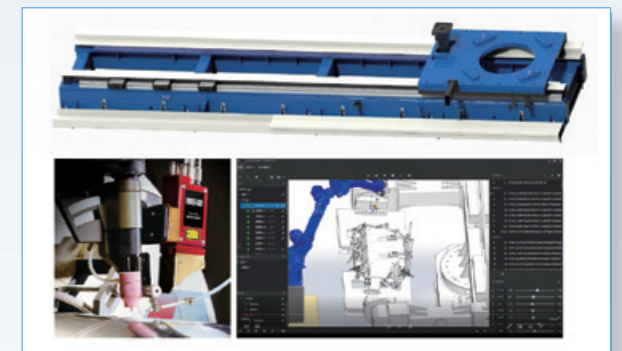

三维五轴充气柜激光焊接机

Five-axis Laser Welding Machine

三维五轴激光焊接专机专注解决各种充气柜的三维焊接，具有产品适应面广、效率高等特点；机器长期运行可靠，精度持久不变；模块化设计、通用型备件、全生命周期服务、尽解后顾之忧。

Five-axis laser welding machine Specialized in 3D welding of Inflatable cabinet, with the characteristics of wide product adaptability and high efficiency, reliable long-term operation and stable precision, modular design, universal spare parts, lifetime service.

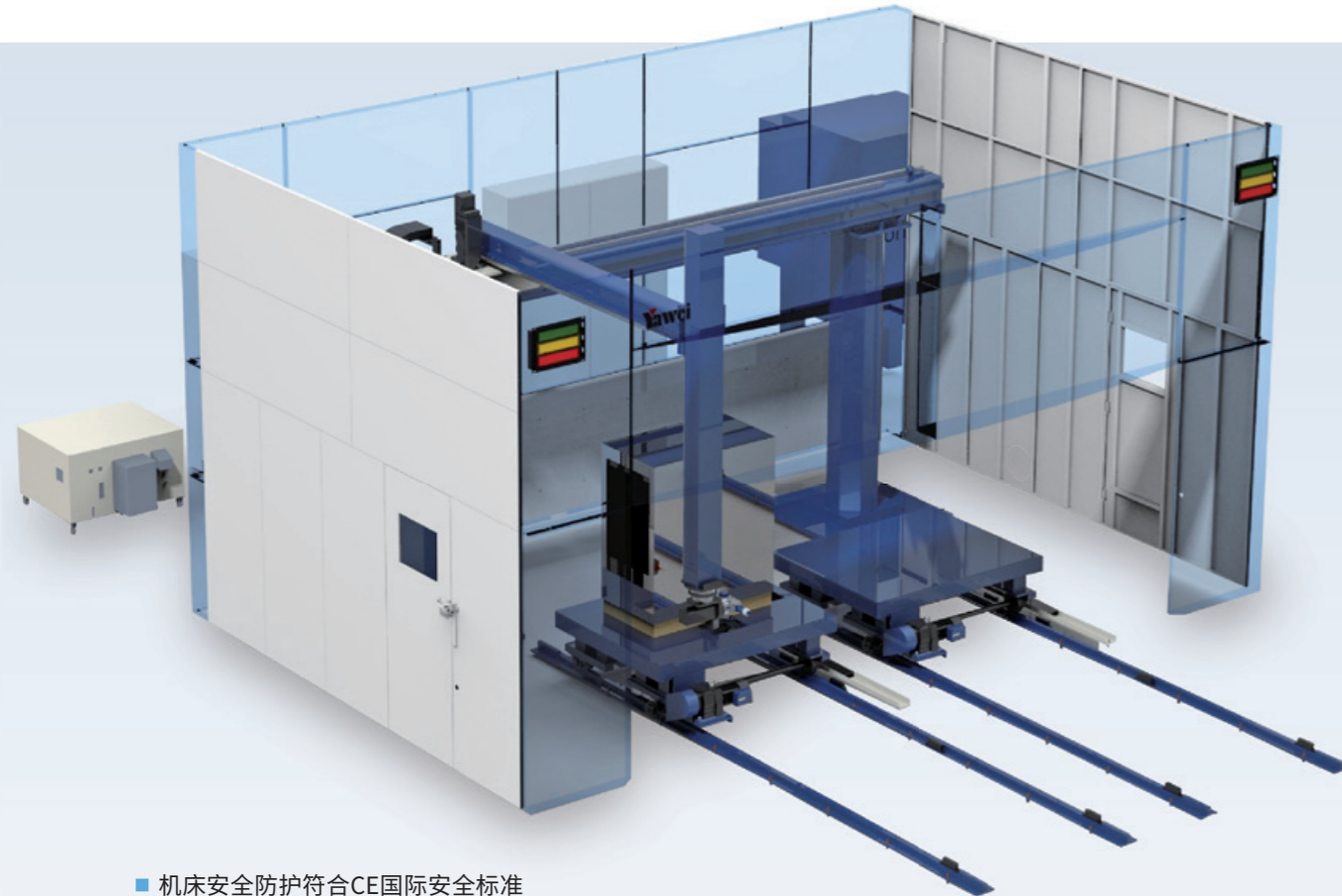

- 机床安全防护符合CE国际安全标准
- 加工幅面4000mm×2000mm，可接受客户定制
- 安装和拆卸区域全开放，方便操作。焊接区域全封闭，保证生产操作人员安全
- 焊接加工区域内架设远程监控用的摄像头，用于对焊接过程的观测
- 双工作台、高速度、高效率
- Machine safety protection complies with CE international safety standards
- The processing size is 4000mm×2000mm, which can be customized
- Installation and disassembly areas are open for easy operation. The welding area is completely closed to ensure the safety of operators
- A remote monitoring camera is installed in the welding processing area to monitor the welding process
- Less cost, easier operation, lower maintenance cost



- 原装进口德国PRECITEC公司的激光焊接头
- 高品质的光学系统和可调整的保护气供给实现高焊接质量，稳定的过程焊接
- The original imported German PRECITEC laser welding head
- High quality optical system and adjustable shielding gas supply to achieve high welding quality, stable process welding



- 采用光纤激光器工业应用的领导者、创新者和最大供应商——德国IPG公司新型先进光纤激光器。广泛应用于各种板材乃至有色金属的加工
- Adopt laser source from IPG, the leader, innovator and largest supplier of fiber optic lasers, has developed a new advanced fiber optic laser. Widely used in all kinds of plate and non-ferrous metal processing



- 采用德国SIEMENS 840DSL数控系统、搭载网络架构新一代原装驱动器及其伺服电机，独立的CNC控制。备有焊接参数库界面，可在界面中实时修改激光焊接工艺参数及更加智能化的操作功能
- Adopts Germany SIEMENS 840DSL CNC system, equipped with a new generation of network architecture original driver and servo motor, independent CNC control. Equipped with the interface of welding parameters library, the laser welding process parameters can be modified in real time in the interface and more intelligent operation functions



- 采用国际先进的单龙门式直线机器人，可以实现远距离工作空间
- 配合先进的二维自由度旋转模块，可实现焊接头的五轴联动加工
- Using the international advanced single gantry linear robot, can achieve long-distance working
- With advanced 2D rotation module, Can achieve Five axis linkage machining by welding head

应用行业-充气柜行业 Application field



性能技术参数 Technical Specification

		项目 Items	单位 Unit	数值 Value
行程 Stroke	X / Y / Z轴行程	X / Y / Z axis stroke	mm	4000 / 2500 / 2000
	C轴转角	Rotating angle of C axis	°	±210
	A轴转角	Rotating angle of A axis	°	720
速度 Speed	X / Y / Z最大速度	X / Y / Z axis max speed	m/s	2.6 / 1.8 / 2.5
	C / A轴最大速度	C / A axis maximum rotation speed	°/s	195
	X / Y / Z重复定位精度	X / Y / Z axis positioning repeat accuracy	mm	±0.02
	C / A轴重复定位精度	C / A axis repeat positioning accuracy	arcmin	1

机器人激光焊接系统

Robot Laser Welding System

机器人激光焊接系统可应用于钣金、厨具、机箱机柜等行业的激光焊接需求，具有产品适应面广、效率高 等特点;机器长期运行可靠，精度持久不变;模块化设计、通用型备件、全生命周期服务、尽解后顾之忧。



- 原装进口德国 PRECITEC 公司的激光焊接头
- 高品质的光学系统和可调整的保护气供给实现高焊接质量，稳定的过程焊接
- The original imported German PRECITEC laser welding head
- High quality optical system and adjustable shielding gas supply to achieve high welding quality, stable process welding



- 采用光纤激光器工业应用的领导者、创新者和最大供应商——德国 IPG 公司新型先进光纤激光器。广泛应用于各种板材乃至有色金属的加工
- IPG, a leader, innovator and largest supplier of fiber optic lasers, has developed a new advanced fiber optic laser. Widely used in all kinds of plate and non-ferrous metal processing



- 采用德国SIEMENS 控制系统，独立的PLC控制。备有焊接参数库界面，可在界面 中实时修改激光焊接工艺参数及更加智能化的操作功能



- 采用国际先进的六轴机器人，可以实现高效、高质量激光焊接

个性化的
上料需求

丰富的配置

量身定制的
工装夹具

个性化的上料需求



配置双工位 P 型双轴变位机



配置双工位首尾相连框架式单轴变位机

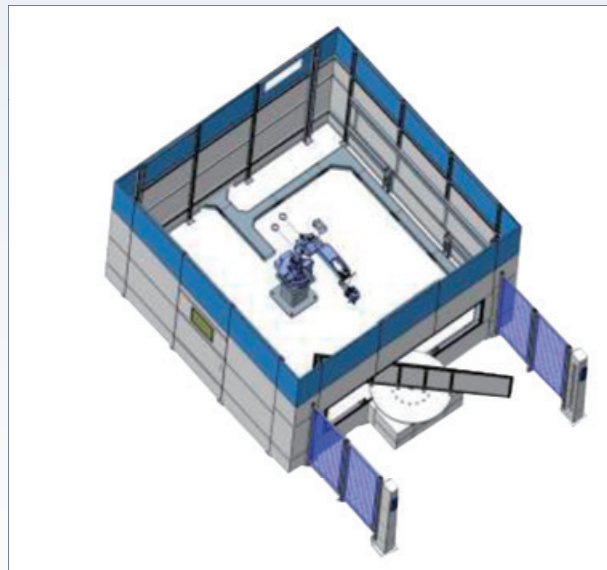

配置水平单轴变位机

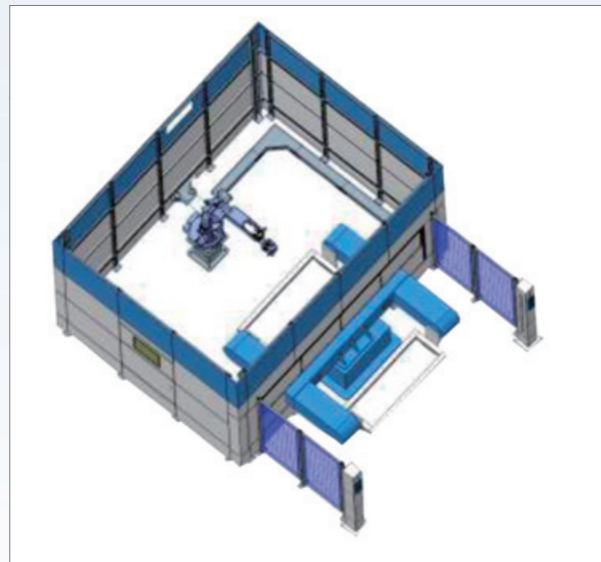

配置水平三轴变位机

性能技术参数 Technical Specification

项目	Items	
激光器参数	激光器	IPG/创鑫 光纤/半导体
	激光器波长	1080/915nm
	平均输出功率	6kw 以下
光纤	光纤型芯	50/100(标配)/200/400um
	光纤长度	20/15m
光学输出特性	聚焦镜头	F=200(标配)/250/300mm
	准直镜头	F=50/75(标配)/100mm
冷却系统	冷却方式	水冷

丰富的配置

■ 选配自动送丝装置:

用于激光焊接过程，为熔池进行不预热填丝的设备。
具有体积小，灵活安装，多种控制方式
模拟量控制、串口、8pin 并口、屏幕控制

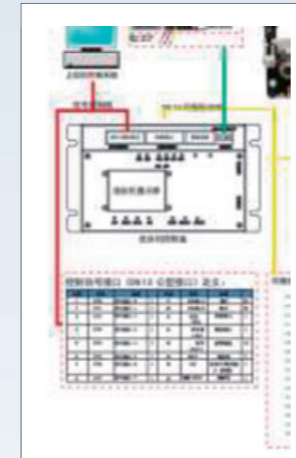

■ 选配激光焊缝自动跟踪装置:

使用激光器、光学传感器和中央处理器，利用光学传播与成像原理，得到激光扫描区域内各个点的位置信息，通过复杂的程序算法完成对常见焊缝的在线实时检测

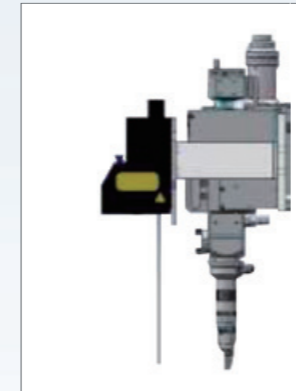

■ 选配激光焊接头防撞装置:

防撞装置是为了保护机器人末端的激光焊接头因发生碰撞而不被损坏，防撞装置的特点包括:自动复位、高重复性、强大的抗力矩和转矩的能力



量身定制的工装夹具

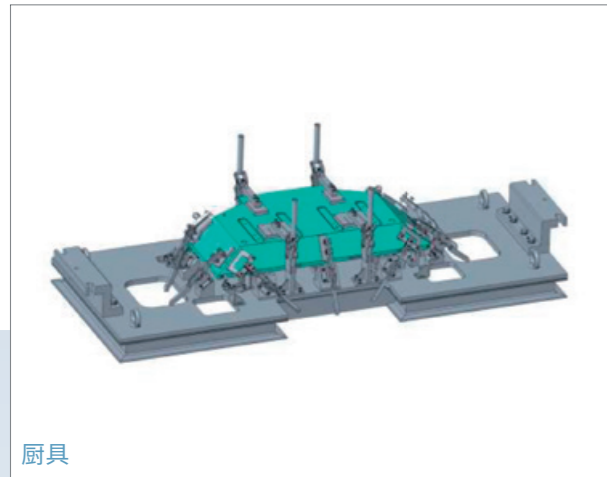

厨具

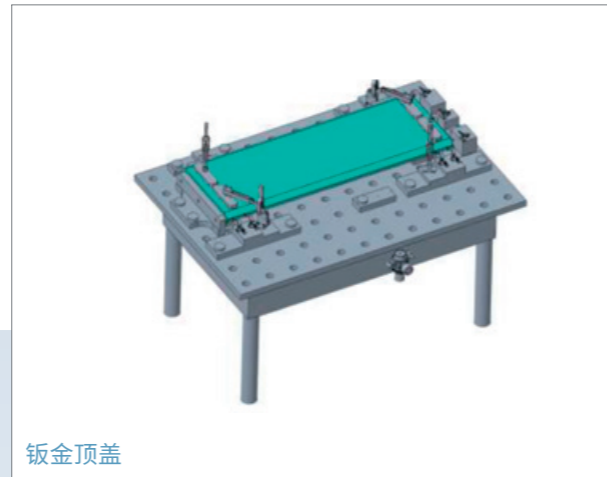

钣金顶盖

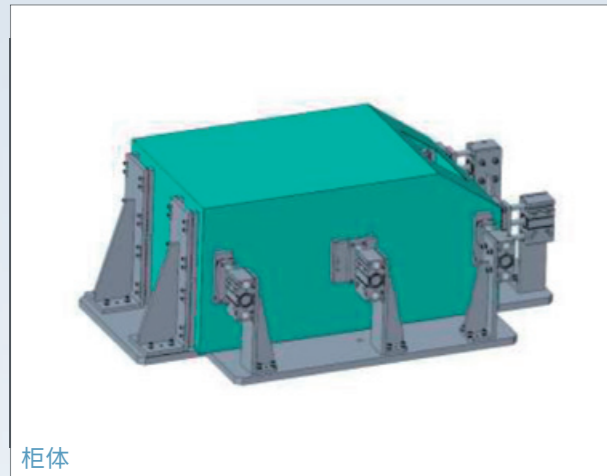

柜体

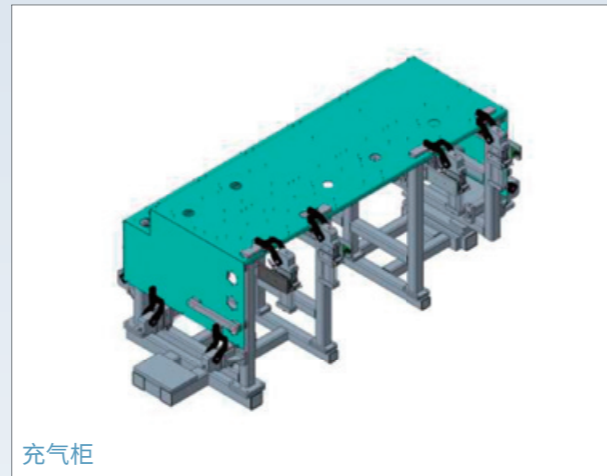

充气柜

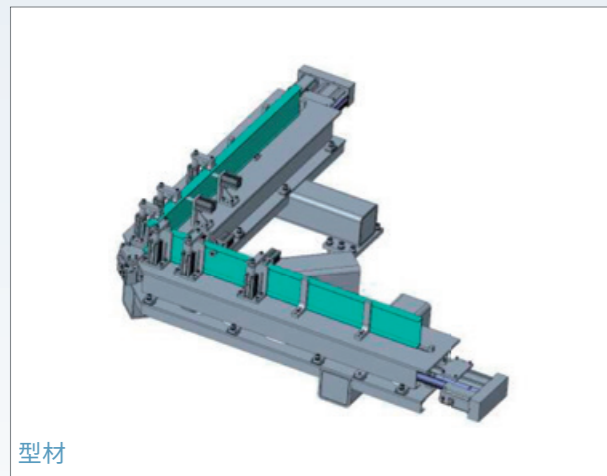

型材

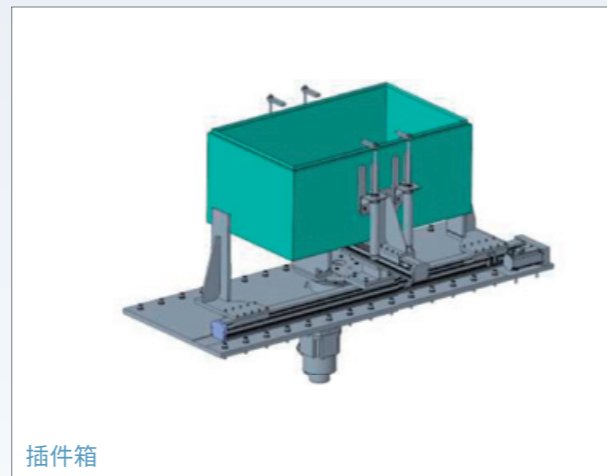

插件箱

YLMW 手持式激光焊接机

手持式激光焊接机与传统焊接机相比，具有操作难度低、焊接速度快、焊接质量高等优点，在薄不锈钢板、钢板、镀锌板、铝板等材料焊接方面，可取代传统 氩弧焊、电焊等工艺，该设备广泛应用于厨具、电梯、电柜、3C等行业。



- 轻量化设计，手持激光头采用高刚性铝合金外壳，重量仅0.8Kg
- 操作简单，结构紧凑，空间占用小
- 配置激光光路保护，避免误出光，操作更安全
- 配置丰富，产品可选配多种材料送丝机构，满足不同材质焊接需求



性能技术参数 Technical Specification

参数名称	YLMW-1501	YLMW-2001
激光器功率	1500W	2000W
接口类型	QBH	
激光入射方式	同轴	
准直焦距	50mm	
聚焦焦距	125/150mm	
摆动范围	1.5mm	
送丝直径	0.8-1.2mm	
最大焊缝熔深		
不锈钢	4mm	5mm
碳钢	4mm	5mm
铝	3mm	4mm

江苏亚威机床股份有限公司

JIANGSU YAWEI MACHINE TOOL CO., LTD.

中国

江苏扬州市江都区黄海南路仙城工业园

邮编: 225200

销售电话: 0514-86880518 86880528 86519118

售后服务: 0514-86880538 86519128 86519158

配件销售: 0514-86519148

传真: 0514-86882218 86519188

网址: www.yawei.cc

电邮: sales1@yawei.cc jgxs@yawei.cc

服务热线: 400-000-2559

INTERNATIONAL

XIANCHENG INDUSTRIAL ZONE, HUANGHAI SOUTH ROAD

JIANGDU DIST. 225200 YANGZHOU, JIANGSU, CHINA

Sales hot line: +86-514-86880517 +86-514-86880518

Service phone: +86-514-86880517 +86-514-86880538

Part sales phone: +86-514-86519148

FAX: +86-514-86880521 +86-514-86882218

HTTP: www.yawei.cc

Email: sales2@yawei.cc



以上两个标志皆为江苏亚威机床股份有限公司的商标
The above two marks both are commercial brand of Jiangsu Yawei Machine Tool Co., Ltd.

产品不断改进, 样本内容可能发生变化, 以亚威提供的技术文件为准
The parameters may change according to product improvements, all should refer to technical documents provided by YAWEI



亚威公众微信
YAWEI WeChat



钣金激光装备事业部微信
Laser Cutting Machine